

MAGNETIC SCALE

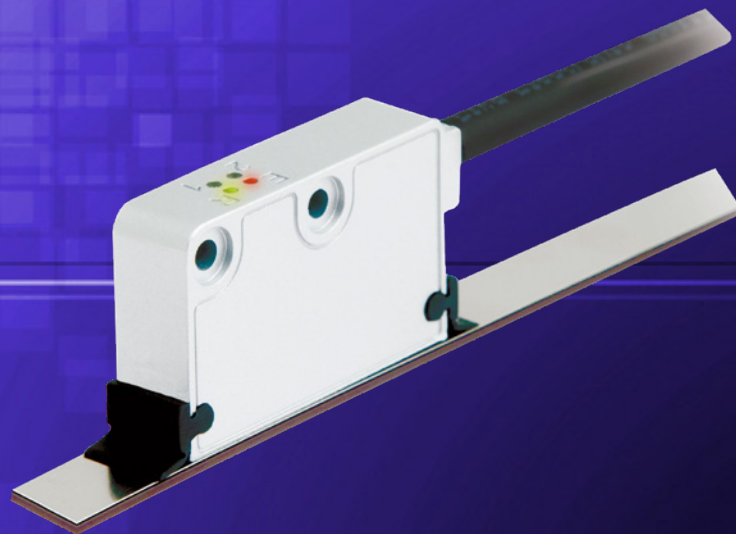

Series MXW21 and MXI21

Key-Features:

- Measurement ranges up to 100 m
- Sine-Cosine 1Vpp real-time output (MXW)
- HTL or TTL output (MXI)
- Unaffected by dust, debris or liquids, IP67
- Hi-flex cable
- High performance encoder for linear motors
- Operating temperature range from -25°C to +85°C

Content:

Technical Data2
Technical Drawing3
Electrical Connection3
Order Code4

TECHNICAL DATA

	Sensor MXW21	Sensor MXI21
Measurement range	max. 99.99 m (tape length - 10 mm)	
Resolution	2000 µm	50, 10, 2 or 1 µm
Sensor linearity	max. 1 % of period length	max. ±15 µm
Repeat linearity	±1 increment	±1 increment
Output circuits	1 Vpp	Line Driver, Push-Pull
Output signals	sine/cosine, ABO / ABO	ABO / ABO
Counting frequency	8 kHz max.	according to edge distance setting ¹⁾
Power supply	+5 VDC ±5 %	+5 VDC ±5 %, 10...30 VDC
Power consumption	70 mA	max. 70 mA
Protection electrical	against short-circuit	against inversion of polarity (except 5 VDC version) and short-circuit
EMC	according to EN 61000-6-2 level 3	
Shock	250 g, 6 ms according to CEI EN 60068-2-27	
Vibrations	10 g, 5-2000 Hz according to CEI EN 60068-2-6	
Protection class	IP67	
Operating temperature range	-25...+85 °C	
Storage temperature range	-40...+100 °C	
Housing material	die cast aluminium, UNI EN AC-46100	
Electrical connection	Hi-flex cable with open wires or cable with connector M12 8 pins	
Gap between sensor/tape (without cover strip)	0.1...1 mm	
Travel speed (mechanical)	max. 16 m/s	

¹⁾ Edge distance selection

Order code	Edge distance (µs)	Max. counting frequency (kHz)	Resolution vs. max. possible speed (m/s)			
			1 µm	2 µm	10 µm	50 µm
H	0.3	3333	2.33	4.67	23.34	14.58
J	0.5	2000	1.4	2.8	14	8.74
A	1	1000	0.7	1.4	7	4.38
B	2	500	0.33	0.67	3.34	2.08
C	4	250	0.18	0.35	1.75	1.09

Magnetic Tape WB20

Length	max. 100 m
Protection class	IP67
Operating temperature range	-20...+70 °C
Storage temperature range	-40...+100 °C
Thermal expansion coefficient	16 * 10 ⁻⁶ / K
Polar pitch	2 mm
Accuracy class	±85 µm/m, ±35 µm/m (up to 30 m), ±8 µm/m (up to 10 m)

Magnetic Tape WB20 Chemical Resistance Information

Acetone	••	Kerosene	•	Seawater	••
Acetylene	••	Ketone	•••	Steam heat	•
Antifreeze (Glacial acetic acid)	•	Mineral / Motor oil	•	Thinner	•••
Benzene	•••	Petrol	••	Turpentine	••
Heptane	•••				

• No effect or low effect •• Low to Medium effect ••• Strong effect

TECHNICAL DRAWING

Sensor MXW21 / MXI21

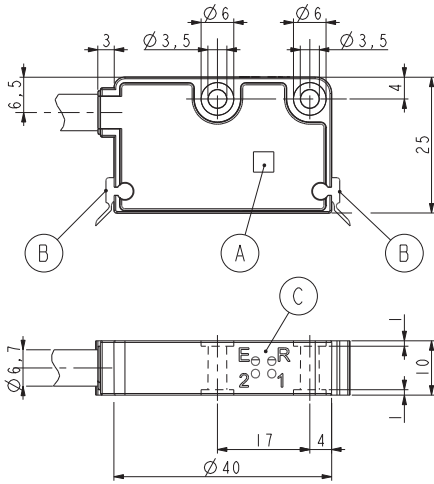

	MXW21	MXI21
A	Reference sensor „R“	
B	Dust wipers	
C	Diagnostic LEDs	Diagnostic LEDs
	E: Gap/Speed error (red) R: Reference detection (green) 1: Output A (green) 2: Output B (green)	E: Gap/Speed error (red) R: Reference detection (green) 1: LED 1 (not used) 2: LED 2 (not used)

Magnetic Tape WB20

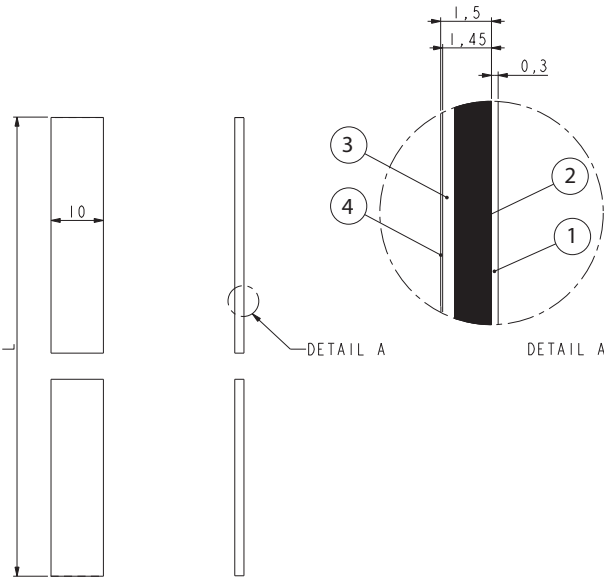

- 1 Cover strip
- 2 Plastoferrite tape
- 3 Carrier with adhesive strip
- 4 Adhesive tape
- L Magnetic tape length

Reference pole support WKM-1309-2

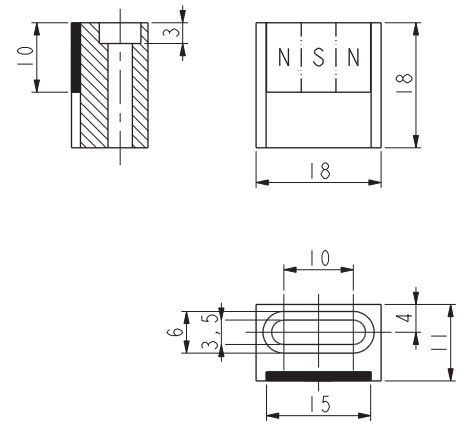

ELECTRICAL CONNECTION

Signals MXW21	Signals MXI21	cable output	connector output	K8PXM-S-M12 ⁴ cable colour
0 VDC	0 VDC	Black	1	White
+5 VDC ±5%	+VDC ²	Red	2	Brown
A	A	Yellow	3	Green
/A	/A	Blue	4	Yellow
B	B	Green	5	Grey
/B	/B	Orange	6	Pink
0 ¹	0 ³	White	7	Blue
/0 ¹	/0 ³	Grey	8	Red
Shielding	Shielding	Shield	Case	Shield

connector output, M12, male

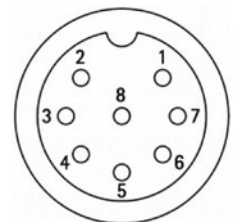

¹ Index (I, K) or Reference (R, T), see the order code; with "N" order code the signal is not provided

² See "order code" page 4.

³ Index (I) or Reference (R), see the order code; with "N" order code the signal is not provided

⁴ See "accessories" page 4. X is cable length in m, e.g. cable length 2 m = K8P2M-S-M12.

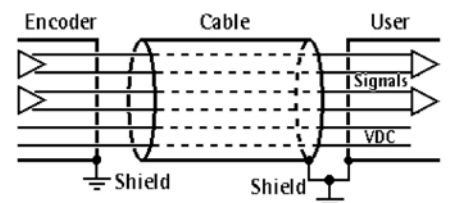

ORDER CODE

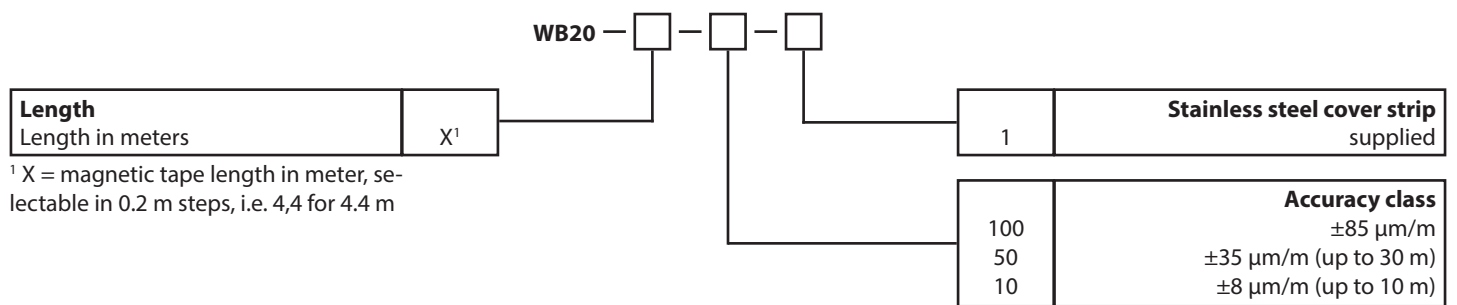
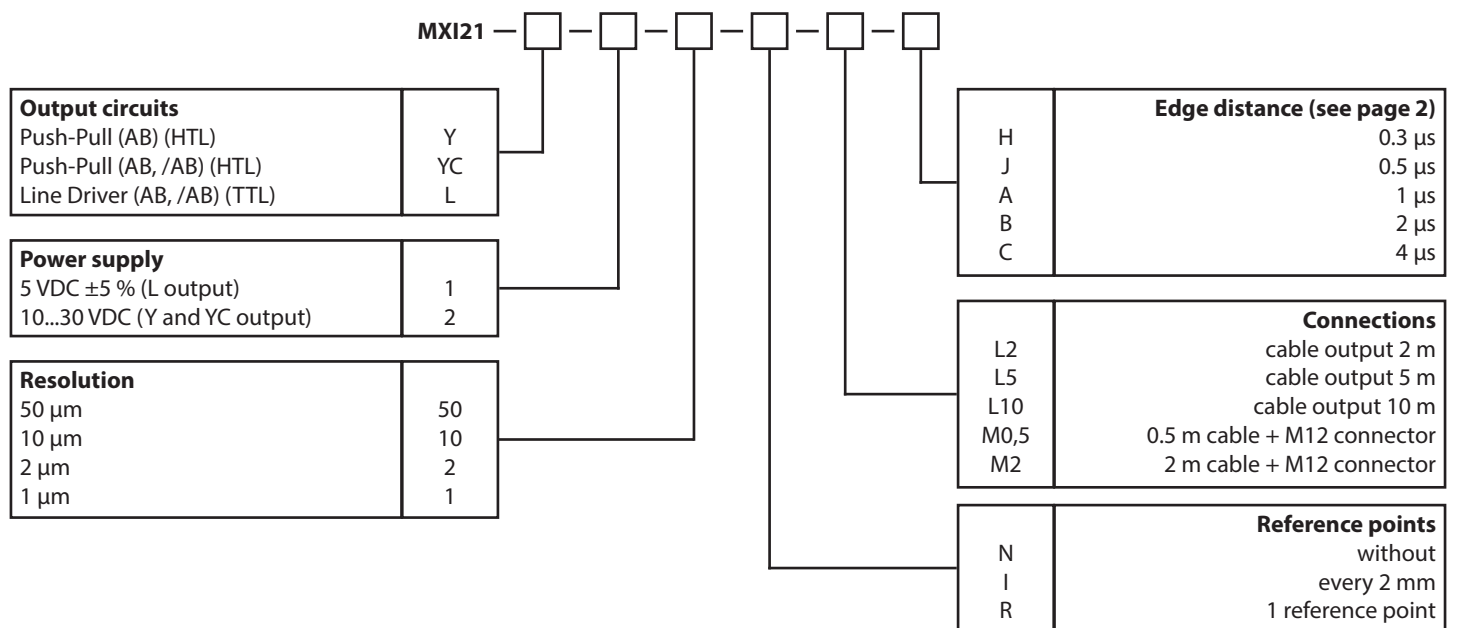
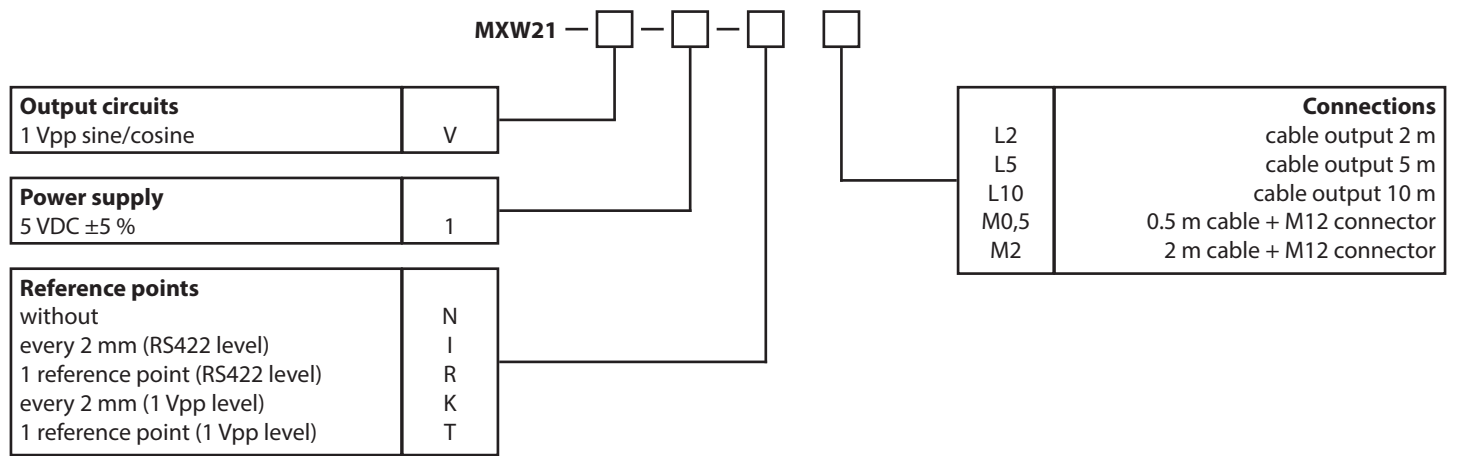

ACCESSORIES

Cables and connectors	
D8-G-M12-S	M12 8 pin mating connector, straight
D8-W-M12-S	M12 8 pin mating connector, angular
K8P2M-S-M12	2 m, connector straight, M12, IP67
K8P5M-S-M12	5 m, connector straight, M12, IP67
K8P10M-S-M12	10 m, connector straight, M12, IP67

Other accessories	
WKM-1309-2	Reference pole for option R and T
KIT WIPERS	Wipers (10 pcs)

Subject to change without prior notice.

WayCon Positionsmesstechnik GmbH
email: info@waycon.de
internet: www.waycon.biz

Head Office
Mehlbeerstr. 4
82024 Taufkirchen
Tel. +49 (0)89 67 97 13-0
Fax +49 (0)89 67 97 13-250

Office Köln
Auf der Pehle 1
50321 Brühl
Tel. +49 (0)2232 56 79 44
Fax +49 (0)2232 56 79 45

